

## SIZE

- Overall Length 420cm
- Inside Length 270cm
- Overall Width 215cm
- Inside Width 107cm
- Weight 6 1 0 lbs
- Tube Diameter 50cm
- # of Air Chambers 3
- PVC Thickness 0.9mm

## CAPACITY

- Max Load 791kg or 1743bs
- Max # people 8
- Max Motor 7 0 HP
- Max Motor Weight 254kg or 560 lbs
- Transom Height 21"
- Max Tube Pressure 3.6 psi

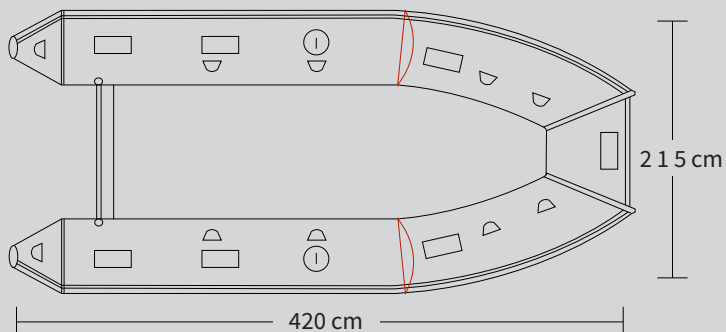



## FEATURES

- Entirely Thermowelded Seams
- Integrated transom supports
- 3mm Aluminum hull
- 0.9mm Heytex PVC tube
- Stryker Shield™ Keel Strake
- Stryker Shield™ Under Tubes
- Side steps w EVA
- Anti Over-Inflation Safety Valve
- Reinforced Tube to Transom
- Fiberglass step
- Exterior Water Redirecting Strake
- Handle @ Bow
- Tow Rope
- 2 Tow Rings on aluminum hull
- Bow locker
- Removable seat with EVA
- One Way Drain Valve
- Carry Handles
- Fiberglass console with center seat
- Aluminum Engine Mounting Plate
- Built in fuel tank 55L
- Bow step with lights and anchor bolt

### INCLUDED IN BOX

- Fiberglass console with front seat
- Electrical pack for boat & console --
- including bilge pump & port/starboard lights on bow
- boarding step, multifunction panel switches, power
- master switch, fuel gauge;
- Aluminum Oars
- Foot Pump
- Repair Kit
- 
- 
-