

JET ULTRA 470

All the features of our JET, with entire belly of boat covered in 1.5 mm American made Thermoplastic Polyurethane (TPU), instead of Stryker Shield, which allows the boat to slide over obstacles easier.

SPECIFICATIONS

SIZE

○ Overall Length	470cm or 15' 4"
○ Inside Length	346cm or 11' 3"
○ Overall Width	205cm or 6' 7"
○ Inside Width	90cm or 2' 10"
○ Weight	104 kg or 229 lbs
○ Tube Diameter	20"
○ # of Air Chambers	5 in body, 1 in floor & 2 removable top tubes
○ PVC Thickness	1.8mm & .9mm

CAPACITY

○ Max Load	1595kg or 3516lbs
○ Max # people	21
○ Max Motor	94 HP
○ Max Motor Weight	203kg or 448 lbs
○ Transom Height	20"
○ Max Tube Pressure	3.6 psi

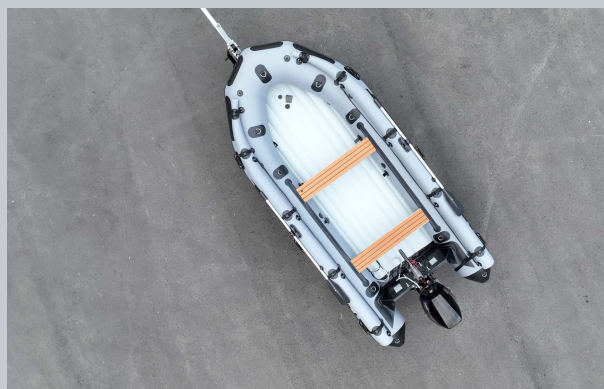
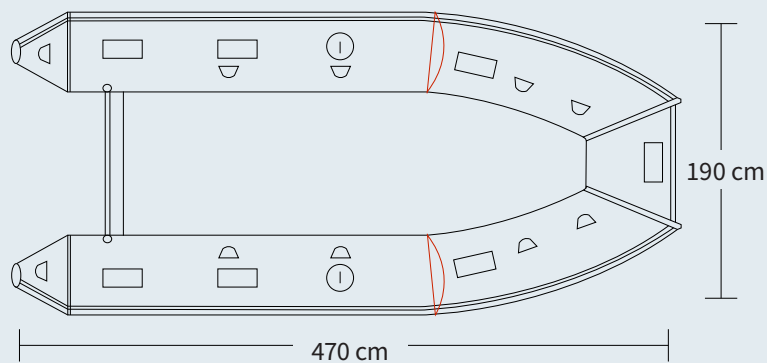

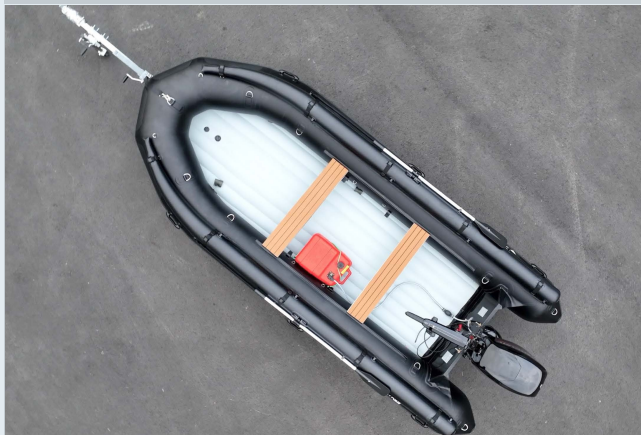

FEATURES

- Entirely Thermowelded Seams
- Aluminum Transom
- 1.8mm Underbelly
- Textured Protective Layer Over Air Floor
- Full TPU Coverage Under Boat
- Sliding EVA Bench Seats
- Removable Top Tubes
- Anti Over-Inflation Safety Valve
- Reinforced Tube to Transom
- Life Line
- Exterior Water Redirecting Strake
- D Handle @ Bow
- Tow Rope
- 2 Tow Rings
- Oar Locks
- Oar Holders
- One Way Drain Valve
- 6 Carry Handles
- Interior D Rings
- Integrated Engine Mount Plate
-
-

INCLUDED IN BOX

- 2 x Aluminum Bench Seat
- Seat Bag
- Aluminum Oars
- Boat Bag
- Essentials Bag
- Foot Pump
- Repair Kit